

Delta 3+1 Robot
IP65 protection class

CR_UGD4MINI Series

USER'S MANUAL

OMRON

Safety Instructions

1. Attention	S-1
2. Explanation of warnings and notes	S-1
3. Safety information	S-2
3.1 General	S-2
3.2 Qualified personnel	S-2
3.3 Liability	S-2
3.4 Installation and operating conditions	S-2
3.5 Residual risks	S-2
3.5.1 Release device	S-3
3.5.2 Transport	S-3
3.5.3 Assembly and start-up	S-3
3.5.4 Maintenance and repair	S-3
3.5.5 System integrator	S-4

Chapter 1 Introduction

1. Introduction	1-1
1.1 Description of the robot	1-1
1.2 Type code explanation	1-1
2. Identification	1-1
3. Part names	1-2

Chapter 2 Model overview

1. Overview	2-1
-------------	-----

Chapter 3 Installation

1. Unpacking	3-1
1.1 Unpacking the shipping box	3-1
1.2 Check the damage	3-1
1.3 Lifting and transportation	3-1
2. Mounting the robot	3-3
3. Mounting the motors and cabling	3-4
3.1 Mounting the motors	3-4
3.2 Connecting the cables	3-4

3.3	Mounting the motor covers	3-5
3.4	Mounting the rotation motor or gearbox with his adaptor ring	3-6
4.	Assembling the secondary arms	3-7
4.1	Make an assembly	3-7
4.2	Mount the arm assembly on the robot	3-8
5.	Mounting the rotational axis on the motor/gearbox shaft	3-9
6.	Calibration	3-10
7.	Gripper interface	3-11
<hr/> Chapter 4 Maintenance		
1.	Periodic maintenance	4-1
1.1	Springs	4-1
1.2	Ball bearing cups	4-2
1.3	Rotational axis	4-2
2.	Cleaning the robot	4-4
3.	Spare parts	4-4
<hr/> Chapter 5 Robot settings		
1.	Kinematics	5-1
2.	Workspace	5-2
3.	Software limits	5-3
<hr/> Chapter 6 Specifications		
1.	Basic specifications	6-1
1.1	Cycle time	6-2
2.	External view and dimensions	6-3
3.	External view and dimensions (Robots with serial number 1784 or lower)	6-4
4.	Design specifications	6-5
4.1	Occupation area of robot	6-5
4.2	Software design	6-6
4.2.1	Dimensions and limits	6-7

Safety Instructions

Contents

1. Attention	S-1
2. Explanation of warnings and notes	S-1
3. Safety information	S-2
3.1 General	S-2
3.2 Qualified personnel	S-2
3.3 Liability	S-2
3.4 Installation and operating conditions	S-2
3.5 Residual risks	S-2
3.5.1 Release device	S-3
3.5.2 Transport	S-3
3.5.3 Assembly and start-up	S-3
3.5.4 Maintenance and repair	S-3
3.5.5 System integrator	S-4

1. Attention

Information in this document can change without prior notice.

OMRON EUROPE B.V. cannot be held responsible for any damage to the environment, to the machine or to the functioning of the machine occurred by errors or missing data in the illustrations, drawing or specifications.

No part of this manual and added documentation may be copied, reproduced or translated into another language without prior written approval.

Read and understand the material contained in this user's manual before you work on the CR_UGD4MINI robot for the first time. This user's manual is supposed to help you use the capabilities of the CR_UGD4MINI robot safely and properly.

2. Explanation of warnings and notes

This manual uses the following safety alert symbols and signal words to provide safety instructions that must be observed and to describe handling precautions, prohibited actions, and compulsory actions. Make sure you understand the meaning of each symbol and signal word and then read this manual.

**DANGER**

THIS INDICATES AN IMMEDIATELY HAZARDOUS SITUATION WHICH, IF NOT AVOIDED, WILL RESULT IN DEATH OR SERIOUS INJURY.

**WARNING**

THIS INDICATES A POTENTIALLY HAZARDOUS SITUATION WHICH, IF NOT AVOIDED, COULD RESULT IN DEATH OR SERIOUS INJURY.

**NOTE**

Explains the key point in the operation in a simple and clear manner.

3. Safety information

3.1 General

This '3. Safety information' subchapter contains information regarding working with the CR_UGD4MINI robot. Qualified personnel working with the CR_UGD4MINI robot must have read and understood the CR_UGD4MINI robot documentation, including the safety information chapter.

3.2 Qualified personnel

These are people who, due their specialist training, knowledge and experience, and their familiarization with the relevant standards, are able to assess the work to be carried out and detect any potential hazards.

3.3 Liability

The CR_UGD4MINI robot is build using state-of-the-art technology and in accordance with the recognized safety rules. Nevertheless, misuse of the CR_UGD4MINI robot may constitute a risk to life and limb or cause damage to the CR_UGD4MINI robot and to other material property.

3.4 Installation and operating conditions

You may only use the components in accordance with the installation and operating conditions described in the documentation. The operating conditions at the installation location must be checked and maintained in accordance with the required technical data. Within the meaning of the Machinery Directive the CR_UGD4MINI robot is an incomplete machine. Commissioning is prohibited until the usable machine or system in which the CR_UGD4MINI robot is installed meets all requirements of the Machine directive 2006/42/EC.

For the CR_UGD4MINI robot you have to observe the following standards, directives and regulations:

- EN ISO 10218-1:2011 Robots and robotic devices - Safety requirements for industrial robots - Part 1: Robots.
- EN ISO 10218-1:2011 Robots and robotic devices - Safety requirements for industrial robots - Part 2: Robot systems and integration.

3.5 Residual risks

Safety and health risks arising from the robot mechanics have been reduced by means of safety technology and design engineering. However a residual risk remains, since the robot mechanics will be move by an automated control system.

The following are typical warnings concerning residual risks which cannot be assigned to a specific action. The expression of safety labels is identical to the safety information.

3.5.1 Release device

The robot mechanics are not supplied with an release switch to control the brakes of the motors.

**WARNING**

- MOUNT A RELEASE SWITCH ON THE MACHINE SO THE ARMS (MOTOR) OF THE ROBOT COULD BE MANUALLY MOVED.
 - MOVING AN AXIS WITH AN IMPROPERLY WORKING RELEASE SWITCH CAN DAMAGE THE MOTOR BRAKE. THIS CAN RESULT IN PERSONAL INJURY AND MATERIAL DAMAGE.
 - BEFORE RELEASING THE BRAKE, YOU HAVE TO BE SURE THAT NO ONE IS IN THE HAZARD AREA OF THE ROBOT.
-

3.5.2 Transport

The prescribed transport position of the robot must be observed. Transportation must be carried out in accordance with the transportation instructions or assembly instructions of the robot.

**WARNING**

- ONLY USE AUTHORIZED HANDLING EQUIPMENT WITH A SUFFICIENT LOAD-BEARING CAPACITY TO TRANSPORT THE ROBOT.
 - WEAR SUITABLE PROTECTIVE CLOTHING IF NECESSARY.
-

3.5.3 Assembly and start-up

Before starting up systems and devices for the first time, a check must be carried out to ensure that the system and devices are completed and operational, that they can be operated safely and that any damage is detected.

The valid national or regional work safety regulations must be observed for this check. The correct functioning of all safety circuits must also be tested.

The following tests must be carried out before start-up and recommissioning. It must be ensured that:

- The robot is correctly installed and fastened in accordance with the specifications in the assembly instructions.
- There are no foreign bodies or loose parts on the robot.
- All required safety equipment is correctly installed and operational.

**WARNING**

- A WRONG INSTALLED ROBOT MAY THROW OFF HIS ARMS.
 - WEAR SUITABLE PROTECTIVE CLOTHING IF NECESSARY.
-

3.5.4 Maintenance and repair

After maintenance and repair work, checks must be carried out to ensure the required safety level. The valid national or regional work safety regulations must be observed for this check. The correct functioning of all safety circuits must also be tested.

The purpose of maintenance and repair work is to ensure that the system is kept original or, in the event of a fault, to return the system to an operational state. Repair work includes troubleshooting in addition to the actual repair itself.

The following safety measures must be carried out when working on the robot:

- Switch of the machine (system) where the robot is built-in (e.g. with a padlock) to prevent it from being switched on again
- Label the machine (system) with a sign indication that work is in progress. This sign must remain in place, even during temporary interruptions to the work.
- The emergency stop from the machine (system) must remain active. If safety functions or safeguards are deactivated during maintenance or repair work, they must be reactivated immediately after the work is completed.

3.5.5 System integrator

The robot is safely integrated into a complete system by the system integrator. The system integrator is responsible for the following tasks:

- Installing the robot
- Performing risk assessment
- Implementing the required safety functions and safeguards
- Issuing the declaration of conformity
- Attaching the CE mark
- Creating the operating instructions for the complete system

Chapter 1 Introduction

Contents

1. Introduction	1-1
1.1 Description of the robot	1-1
1.2 Type code explanation	1-1
2. Identification	1-1
3. Part names	1-2

1. Introduction

Congratulations with the purchase of your high speed Delta robot. This is a high speed pick and place robot which uses state-of-the-art carbon composite materials and the latest servo drive technology to be put in use in the most demanding pick and place applications.

This manual should be read before the commissioning of the robot. By mechanical engineers in the design phase during the integration of the robot in the machine and by software engineers to check the performance envelope of the robot.

This manual describes the main versions of the CR_UGD4MINI robot, and all options. Where applicable check the appropriate data for your robot type, the type can be found on the identification tag of the robot.



CR_UGD4MINI



CR_UGD4MINI_TS
(stainless steel + titanium secondary arms)

1.1 Description of the robot

The CR_UGD4MINI Delta robot is a high speed pick and place robot which uses state-of-the-art carbon composite materials and the latest servo drive technology to be put in use in the most demanding pick and place applications. The robot is designed as a 3-axis (optional 4th rotational axis) Delta kinematic system.

Characteristics of the robot:

- Requires very low maintenance
- 3 + 1 (rotational axis optional) degrees of freedom
- Compact design for mounting in a machine
- Low noise level < 68 dB (A)

1.2 Type code explanation

Standard models

CR_UGD4MINI_R: 3 + 1 axes (with rotational axis), 500 mm working range, max. payload: 1 kg

CR_UGD4MINI_NR: 3 axes (without rotational axis), 500 mm working range, max. payload: 1 kg

Models with stainless steel + titanium secondary arms

CR_UGD4MINI_R_TS: 3 + 1 axes (with rotational axis), 500 mm working range, max. payload: 1 kg

CR_UGD4MINI_NR_TS: 3 axes (without rotational axis), 500 mm working range, max. payload: 1 kg



NOTE

Robots with serial number 1784 or lower have different working range. Refer to "3. External view and dimensions (Robots with serial number 1784 or lower)" in Chapter 1 for more detailed information about dimensions.

2. Identification

On the robot base plate an identification tag is mounted, important data on this plate:

- Robot type
- Total weight of the robot
- Year of production
- Serial number, important for ordering spareparts

3. Part names

1

CR_UGD4MINI

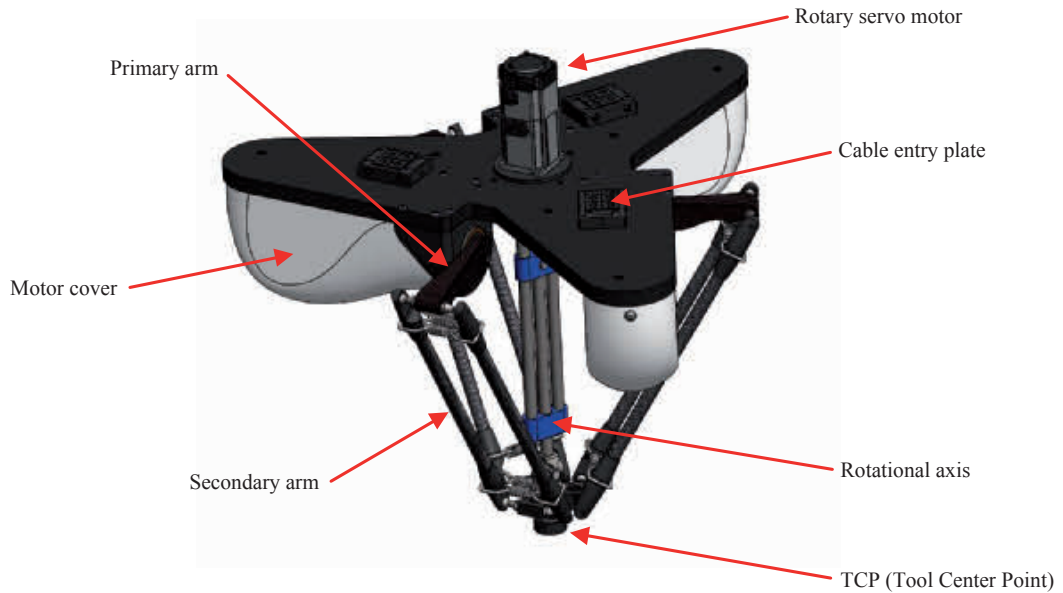

The CR_UGD4MINI robot consists of three radially placed axis which give the TCP freedom to move in three directions, X, Y and Z. An optional fourth axis can take care of the rotation, Rz, of the TCP.

Optionally the robot is equipped with an extra servo motor for the rotational axis.

Chapter 2 Model overview

Contents

1. Overview

2-1

1. Overview

The CR_UGD4MINI has a working range of 500 mm. The specifications are given in the below figure, if specifications differ for models, for instance with- or without rotation axis, it is indicated in the specification list.

The Mini Delta robot models are delivered standard with sanitary secondary arms, this means they are fully closed to prevent any contamination on the inside of the secondary arms.

CR_UGD4MINI (500 mm)

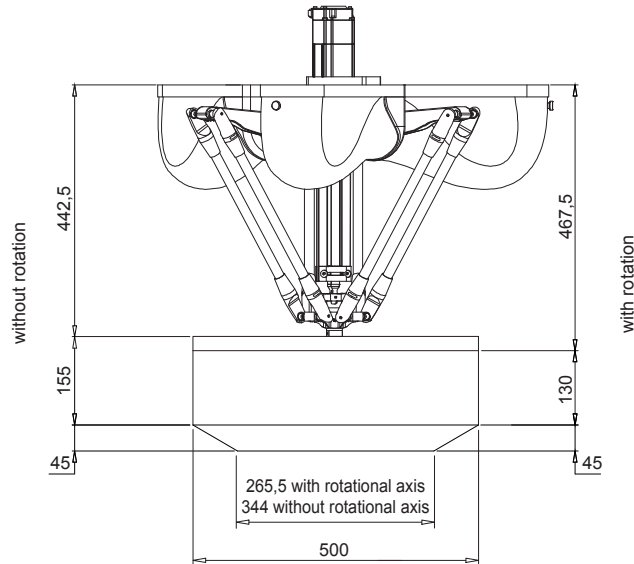

NOTE

Note that the rotation servo motor, on the top of the robot, is optional.



NOTE

Robots with serial number 1784 or lower have different dimensions. Refer to "3. External view and dimensions (Robots with serial number 1784 or lower)" in Chapter 1 for more detailed information about dimensions.

Chapter 3 Installation

Contents

1. Unpacking	3-1
1.1 Unpacking the shipping box	3-1
1.2 Check the damage	3-1
1.3 Lifting and transportation	3-1
2. Mounting the robot	3-3
3. Mounting the motors and cabling	3-4
3.1 Mounting the motors	3-4
3.2 Connecting the cables	3-4
3.3 Mounting the motor covers	3-5
3.4 Mounting the rotation motor or gearbox with his adaptor ring	3-6
4. Assembling the secondary arms	3-7
4.1 Make an assembly	3-7
4.2 Mount the arm assembly on the robot	3-8
5. Mounting the rotational axis on the motor/gearbox shaft	3-9
6. Calibration	3-10
7. Gripper interface	3-11

1. Unpacking

1.1 Unpacking the shipping box

The robot comes in a special shipping box.

The following step must be carried out to remove the cover from the box:

- Unscrew the screws from the cover of the wooden box
- Now remove the cover

1.2 Check the damage

First take out the individual components from the package and check that everything is complete according to the following list:

- 1 x rotational axis (in case of CR_UGD4MINI_R or CR_UGD4MINI_R_TS models)
- 1 x adaptor ring for the rotational axis gear or motor (in case of CR_UGD4MINI_R or CR_UGD4MINI_R_TS models)
- 1 x TCP - Tool Center Point (in case of CR_UGD4_NR or CR_UGD4_NR_TS models)
- 6 x secondary arms
- 6 x spring package (12 x spring brackets and 12 x spring)

Check all the components and the robot for transportation damage.

1.3 Lifting and transportation

Before the robot is lifted, it must be ensured that it is free from obstructions.

Remove all the screws where the robot is mounted with in the box.

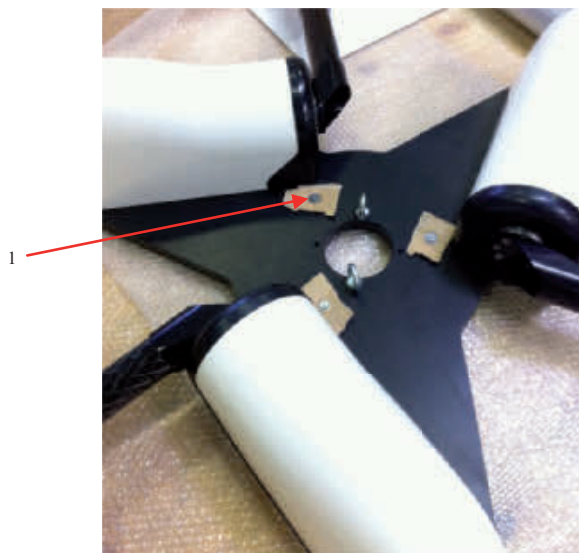

No.	Description
1	3 x screws with protection material

The robot must be lifted and transported by using lifting tackle or a forklift truck. Two lifting straps has to be attached into two eyebolts that are screwed into the baseplate. The lifting straps has to be long enough and must be routed in such a way that the robot is not damaged.

**WARNING**

- THE ROBOT MAY TILT DURING TRANSPORTATION.
- ADDITIONAL SAFEGUARDING MEASURE MUST BE TAKEN.
- WEAR SUITABLE PROTECTIVE CLOTHING IF NECESSARY.
- WHEN USING A FORKLIFT TRUCK, DRIVE EXTREMELY SLOWLY AND CAREFULLY.

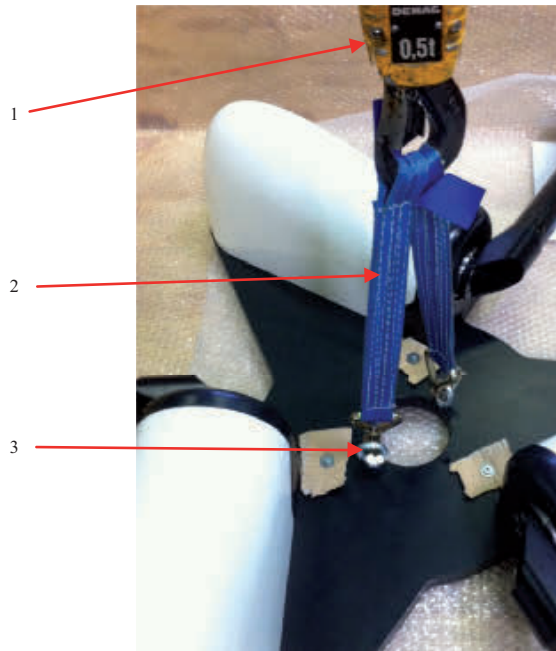

No.	Description
1	Lifting tackle
2	2 x lifting straps
3	2 x eyebolts

2. Mounting the robot

The mounting surface for the robot must be machined and of an appropriate quality. It's also possible to use a levelling element to align the robot.

Three M12 bolts are needed to mounting the robot to the frame, exact bolt length depends on frame layout. The tightening torque of a M12 6.8 bolt is 63Nm.

The below figure shows the mounting pattern from the robot.

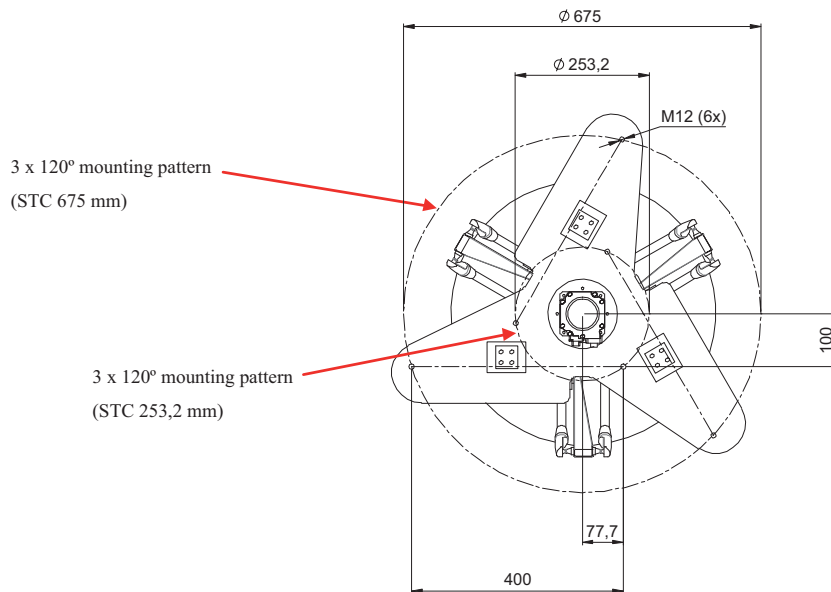

NOTE

It is advisable to put one motor of the robot in line with the direction of the transport belt to make programming easier.



NOTE

Robots with serial number 1784 or lower have different dimensions. Refer to "3. External view and dimensions (Robots with serial number 1784 or lower)" in Chapter 1 for more detailed information about dimensions.

3. Mounting the motors and cabling

3.1 Mounting the motors

When your robot is delivered without motors, you have to mount them by yourself. First of all you have to remove the three motor covers from the robot.

The following steps must be carried out to remove the motor covers from the robot. Please see also the following picture:

- Remove the M6 Allen bolt



No.	Description
1	1 x M6 Allen bolt
2	Motor cover

- Remove the motor cover
- Repeat this process for the other two motor covers

3.2 Connecting the cables

The robot is delivered with 3 cable entry plates. They are mounted above every primary arm motor to feed his cables through.

The following steps must be carried out to feed the cables through the entry plates. Please see also the below pictures:

- Remove the 4 bolts of the cable entry plates
- Remove the cable entry glands

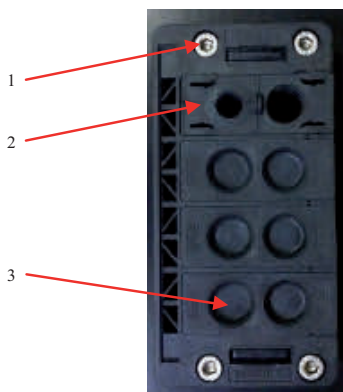

No.	Description
1	4 x M5 Allen bolt
2	Cable entry glands
3	Blind thule

- Insert the cables into the opening of the robot baseplate
- Connect the cables

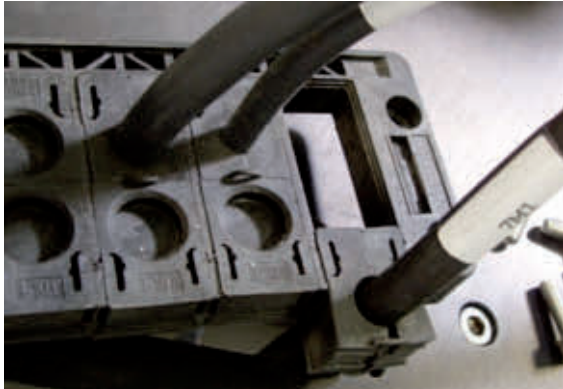

- Clamp the cable entry glands around the cable and slide it back into the cable entry plate. Afterwards also slide the blind thule back into the cable entry plate
- Mount the cable entry plate on the baseplate, using the 4 M5 Allen bolts

3.3 Mounting the motor covers

- Mount the cover in the machined groove
- Install the Allen M6 bolt in the cover bracket and tighten
- Repeat the process for the other two motor covers
- The motor covers are now mounted



No.	Description
1	Cover bracket
2	Machined groove

3.4 Mounting the rotation motor or gearbox with his adaptor ring

This section is applicable only to the CR_UGD4MINI_R and CR_UGD4MINI_R_TS models (with rotational axis).
Dependent on the type of rotation motor or gearbox with rotation motor, a special adaptor ring for mounting is included.

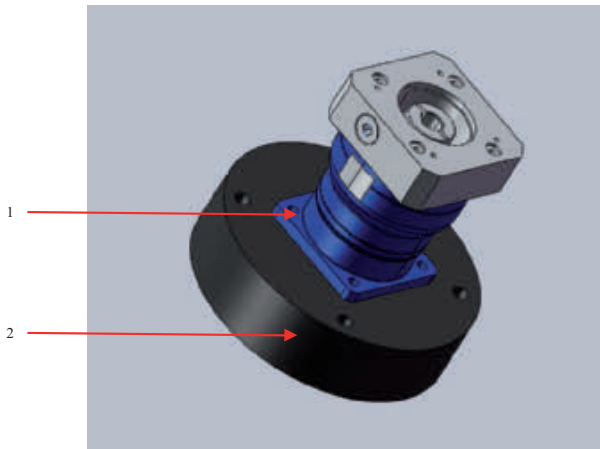

No.	Description
1	Gearbox or motor
2	Adaptor ring

Now mount the adaptor ring (with the motor or gearbox) on the top of the baseplate from the robot with the included bolts and rings.

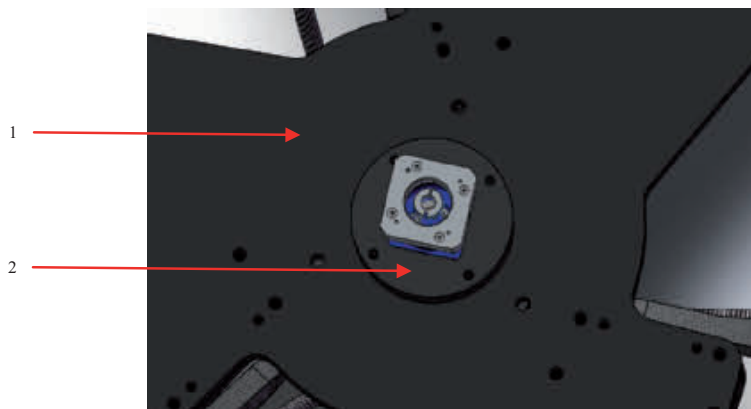

No.	Description
1	Top of the baseplate
2	Rotation adaptor ring with motor or gearbox

4. Assembling the secondary arms

4.1 Make an assembly

Before mounting the secondary arms on the robot, we have to pre-assemble them as shown on the below figure, so that we get an arm assembly.

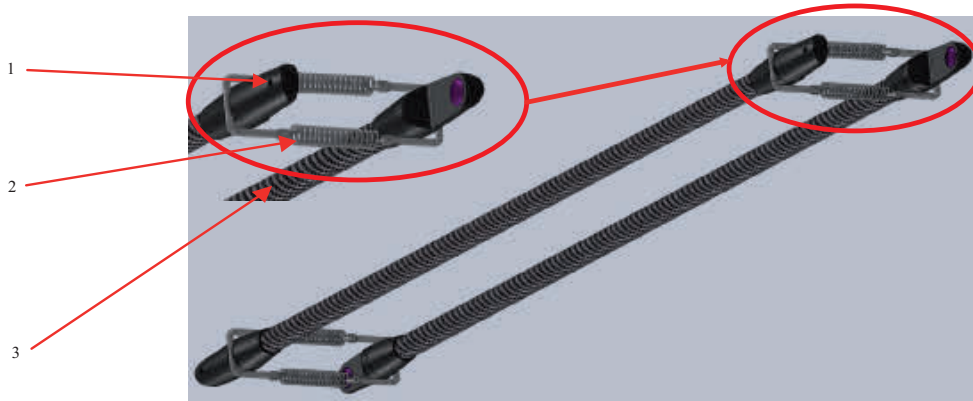

No.	Description
1	Sanitary cup holder incl. ball bearing cup
2	Spring package
3	Secondary arm

Repeat this action for the other 2 arm sets.



WARNING

- INCORRECT MOUNTED SPRINGS CAN JUMP AWAY.
- WEAR SUITABLE PROTECTIVE CLOTHING AND SAFETY GLASSES.
- NEVER PULL THE SPRINGS FURTHER APART THAN NECESSARY WHEN MOUNTING THE ARM ASSEMBLY ON THE PRIMARY ARM OR TCP BALL JOINTS.
- REPLACE SPRINGS AFTER OVERSTRETCHING.

4.2 Mount the arm assembly on the robot

For mounting, pull a secondary arm with his cup holder over the ball joint of the primary arm. Now pull the arms apart against the force of the spring in order to pull the second arm over the second ball joint of the primary arm. Then repeat this action for the TCP (see below picture).

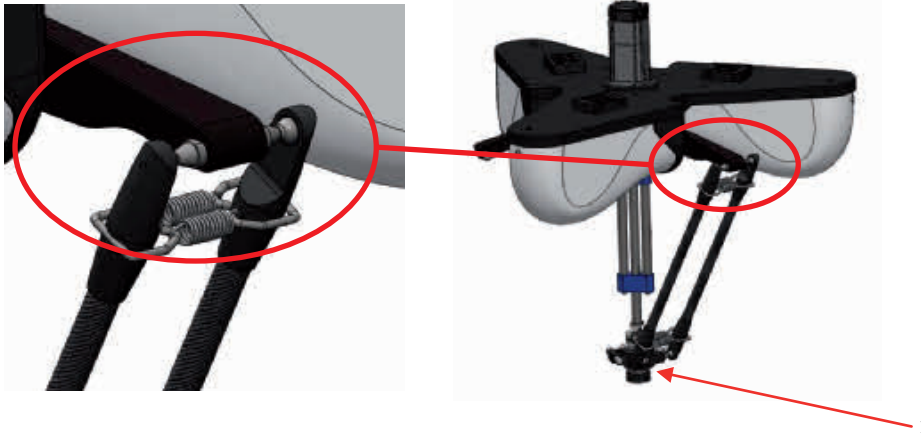

No.	Description
1	TCP - Tool Center Point

Repeat this action for the other 2 secondary arm assembly's.
Now your robot mechanic is completely installed.

5. Mounting the rotational axis on the motor/gearbox shaft

This section is applicable only to the CR_UGD4_R and CR_UGD4_R_TS models (with rotational axis).

Please perform the following steps first.

- Extend the rotational axis to its entire length, then retract the same and check whether it is easy to operate or whether some resistance occurs



NOTE

A light irregular resistance is normal and caused by the manufacturing tolerances of the tubes. The axis is run in during the first 150 hours of operation. In case of problems, please check the axis for damage or contact your OMRON representative.

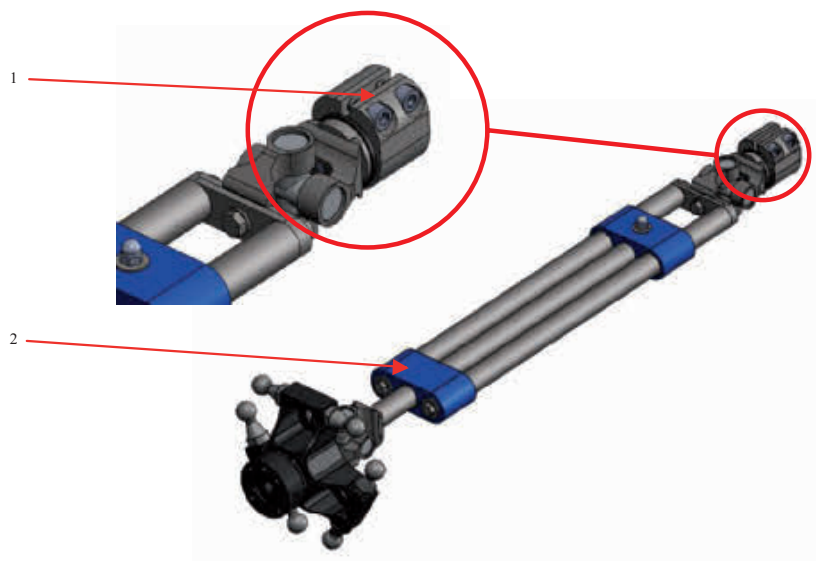

No.	Description
1	Clamping bush with bolts
2	Rotational axis

Release the two M5 Allen bolts which are mounted into the clamping bush (see above picture).

In delivery condition, an extra fill bush is located in the clamping bush.

Measure your motor/gearbox axis and determine if you need the extra fill bush.

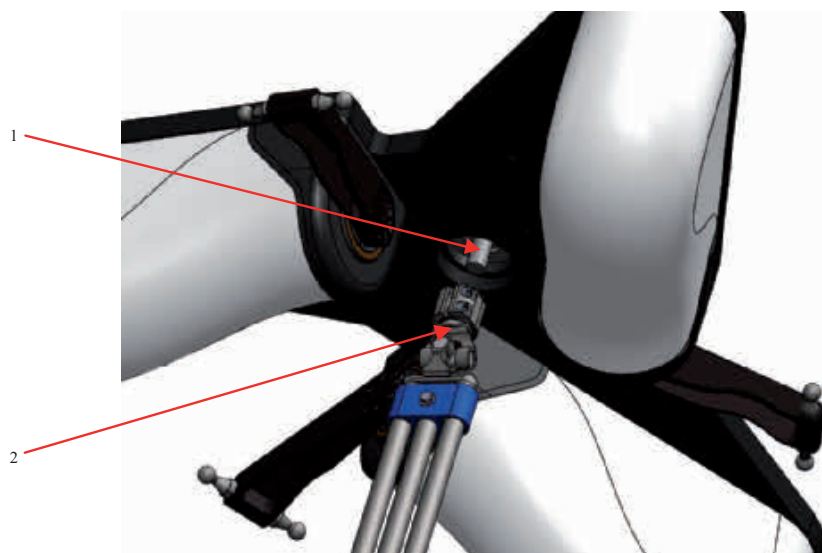

No.	Description
1	Motor or gear shaft
2	Top connector rotational axis

Now push the top connector into the shaft until the top connector comes into its stop position on the shaft. Tighten the two M5 Allen bolts with 7 Nm.

The rotational axis is now mounted.

6. Calibration

Not every robot that is delivered is calibrated.

If you want to calibrate the robot by yourself, a calibration tool is available (shown in the below picture).

The calibration tool can be ordered as CR_AS-2435.



No.	Description
1	Calibration tool

The following steps must be carried out to put the three upper arms from the robot in the zero position. Please see also the below pictures:



- Make sure all the secondary arms are disassembled
- Release the motor brake and make sure all the primary arms are rotated down far enough, so the calibration tool could be mounted
- Slide the calibration tool on the baseplate as shown above
- Now tighten the star nut until the tool is fixed

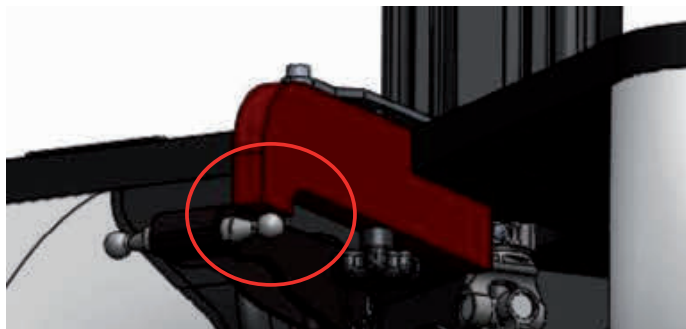

- Release the motor brake from the selected motor and push the upper arm with his ball joint against the calibration tool as shown above
- Now fix the motor brake from the selected motor
- Repeat the calibration steps for the other two primary arms
- Remove the tool



WARNING

- CALIBRATING THE ROBOT MUST BE CARRIED OUT BY QUALIFIED PROGRAMMING PERSONNEL ONLY, AS THIS REQUIRES AN EXCELLENT LEVEL OF KNOWLEDGE OF THE CONTROL SYSTEM.
- WHEN CARRYING OUT THE HOMING YOURSELF, THIS MUST BE CARRIED OUT EXACTLY IN THE WAY AND THE ORDER THAT THEY ARE DESCRIBED.

- Now all the primary arms are in zero position from the kinematic model
- Now put the encoder values from the servo motors in 0°
- Check that the angle indicated for the three motors is $0^\circ (\pm 0.1^\circ)$
- Your robot is now calibrated

7. Gripper interface

The below picture shows you the gripper connection sizes according to ISO 9409-1-A31,5. The gripper connection sizes for the robot with or without rotational axis are the same.

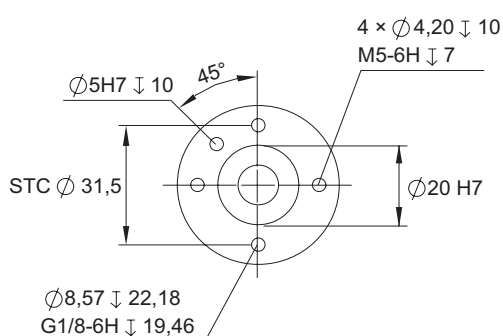

The design of the gripper that is mounted under the robot have great influence on the performance of the robot. Both the weight of the gripper and the distance of the center of gravity of the gripper to the TCP base point have negative influence on the final performance of the robot.

If you need to install cabling for the gripper, please follow the following steps:

- Mount the cables on the baseplate or frame, near the turning point from the primary arm on the gearbox
- Mount the cables on the primary arm, with ty-raps or clamping parts
- Keep a big loop at the hinge point from the primary and secondary arm
- Mount the cables on the secondary arm, with ty-raps or clamping parts
- Keep a big loop from the lowest mounting point at the secondary arm till the connection on the gripper

Chapter 4 Maintenance

Contents

1. Periodic maintenance	4-1
1.1 Springs	4-1
1.2 Ball bearing cups	4-2
1.3 Rotational axis	4-2
2. Cleaning the robot	4-4
3. Spare parts	4-4

1. Periodic maintenance

Before working on the robot, please be ensured that the machine where the robot is built in, is totally switched off.



DANGER

- SWITCH OFF THE MACHINE (SYSTEM) WHERE THE ROBOT IS BUILT IN (E.G. WITH A PADLOCK) TO PREVENT IT FROM BEING SWITCHED ON AGAIN.
- LABEL THE MACHINE (SYSTEM) WITH A SIGN INDICATION THAT WORK IS IN PROGRESS. THIS SIGN MUST REMAIN IN PLACE, EVEN DURING TEMPORARY INTERRUPTIONS TO THE WORK.
- THE EMERGENCY STOP FROM THE MACHINE (SYSTEM) MUST REMAIN ACTIVE. IF SAFETY FUNCTIONS OR SAFEGUARDS ARE DEACTIVATED DURING MAINTENANCE OR REPAIR WORK, THEY MUST BE REACTIVATED IMMEDIATELY AFTER THE WORK IS COMPLETED.

1.1 Springs

How to maintain the springs:

- The springs has to be replaced every 3800 working hours or once a year
- When the robot is fall apart, check the springs on damages
- Replace the springs when they are damaged
- Only use springs delivered by OMRON, otherwise the guarantee will expire
- Replace springs after overstretching
- For spare parts, see **Section 3 Spare parts** in this chapter



WARNING

- INCORRECT MOUNTED SPRINGS CAN JUMP AWAY.
- WEAR SUITABLE PROTECTIVE CLOTHING AND SAFETY GLASSES.
- NEVER PULL THE SPRINGS FURTHER APART THAN NECESSARY WHEN MOUNTING THE ARM ASSEMBLY ON THE PRIMARY ARM OR TCP BALL JOINTS.

How to disassemble the springs:

- Disassemble the secondary arms from the robot
- Replace the springs
- For re-assembling the secondary arms, see **Section 4 Assembling the secondary arms** in Chapter 3

1.2 Ball bearing cups

The ball bearing cups has the same lifetime as the springs. We recommend to exchange these at the same time as the springs.

How to maintain the ball bearing cups:

- The ball bearing cups has to be replaced every 3800 working hours or once a year
- When the ball bearing cups make squeaking noises, take of the secondary arm assembly's and clean the cups with pressed air
- **Do not lubricate the ball bearing cups!**

For instructions to replace the ball bearing cups, see below picture:

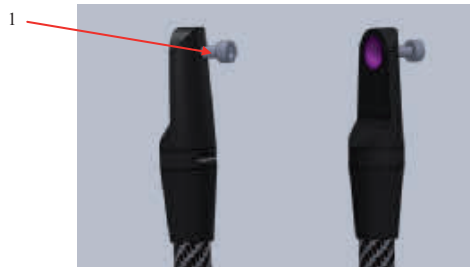

No.	Description
1	M5 bolt

- Screw an M5 bolt in the backside from the cup holder
- Now the ball bearing cup will come out

1.3 Rotational axis

The plain bearings on the rotational axis wear with time so that backlash starts to occur on the rotational axis. How fast the plain bearings become worn depends strongly on the following factors:

- The working path
- The payload
- The speed of the robot
- The rotation actions

When do I have to exchange the plain bearings?

- If there is a lot of play on the rotational axis
- Every 3000 working hours or once a year

For instructions to replace the plain bearings, see the below picture:

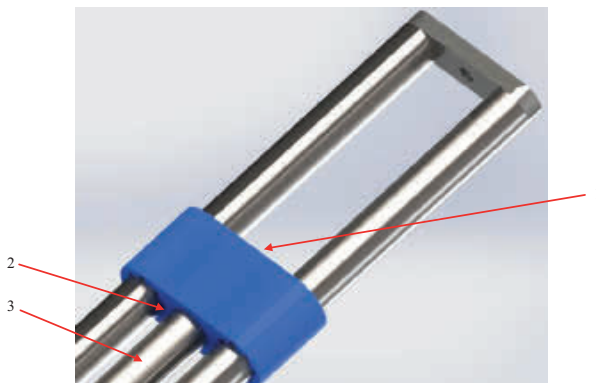

No.	Description
1	M5 bolt with washer
2	Plain bearing
3	Lower rotation tube

- Unscrew the M5 bolt with washer from the upper bearing block
- Remove the lower rotation tube

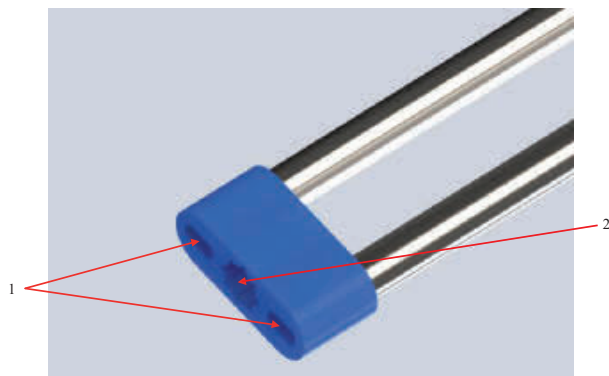

No.	Description
1	2 x M5 bolt with washer
2	Lower plain bearing

- Unscrew the two M5 bolts with washer and take of the old lower and upper plain bearing blocks
- Exchange the three yellow plain bearings with the new ones
- Now put the upper bearing block on the tubes
- Put back the lower bearing block and the 2 x M5 bolt with washer
- Tighten the 2 x M5 bolt
- Now put back the lower rotation tube and mount it with the M5 bolt with washer
- Tighten the M5 bolt



WARNING

- PLAIN BEARINGS HAS TO BE MOUNTED VERY CAREFULLY.
- WRONG MOUNTED PLAIN BEARINGS MAY DAMAGE.
- EXTEND THE ROTATIONAL AXIS TO ITS ENTIRE LENGTH, THEN RETRACT THE SAME AND CHECK WHETHER IT IS EASY TO OPERATE OR WHETHER SOME RESISTANCE OCCURS.

2. Cleaning the robot

Clean the robot by washing with soft cloth or sponge. Use soap or mild detergent and warm water followed by clear water rinse.









For oil and grease stains use alcohol with soft cloth.

Do not use a high pressure water cleaner, or any other high pressure cleaning device.







3. Spare parts

■ Robots with serial number 1785 or higher



Common spare parts (models with/without rotational axis)

Robot part	Description	Quantity per robot	OMRON Part No.
			CR_UGD4MINI_[]
Robot base	1 x motor cover	3	CR_PT-04240 
Primary arm	1 x primary arm	3	CR_AS-00859 
Secondary arm	1 x secondary arm	6	CR_AS-2224 
	1 x secondary arm spring	6	CR_AS-2072 
	1 x ball bearing cup	12	CR_PT-01841 
TCP - Tool Center Point	1 x TCP	1	CR_AS-00861 
Primary arm & TCP	1 x ball joint	12	CR_AS-2920 
Gearbox for primary arm	1 x gearbox	3	CR_GEARP-09 
Calibration tool	1 x calibration tool	1	CR_AS-2435 

Spare parts for models with rotational axis

Robot part	Description	Quantity per robot	OMRON Part No.
			CR_UGD4MINI_R
Rotational axis	1 x mounting clamp with cardan joint	1	CR_AS-2938 
	1 x gripper flange	1	CR_AS-2934 
	1 x complete rotational axis	1	CR_AS-2969 
	1 x upper side rotational axis	1	CR_AS-2970 
	1 x lower tube with cardan joint and TCP	1	CR_AS-2971 
	1 x bearing 8	2	CR_CP-1023 
	1 x plain bearing	4	CR_CP-1000 

Spare parts for models without rotational axis

Robot part	Description	Quantity per robot	OMRON Part No.
			CR_UGD4MINI_NR
TCP - Tool Center Point	1 x shaft axis for gripper flange	1	CR_PT-05298 
	1 x gripper flange	1	CR_PT-05299 

■ Robots with serial number 1784 or lower

Common spare parts (models with/without rotational axis)

Robot part	Description	Quantity per robot	OMRON Part No.
			CR_UGD4MINI_[]
Robot base	1 x motor cover	3	CR_PT-04240
Primary arm	1 x primary arm	3	CR_AS-00859
Secondary arm	1 x secondary arm	6	CR_AS-2224
	1 x secondary arm spring	6	CR_AS-2072
	1 x ball bearing cup	12	CR_PT-01841
TCP - Tool Center Point	1 x TCP	1	CR_AS-00861
Primary arm & TCP	1 x ball joint	12	CR_AS-2920
Gearbox for primary arm	1 x gearbox	3	CR_GEARP-09
Calibration tool	1 x calibration tool	1	CR_AS-2435

Spare parts for models with rotational axis

Robot part	Description	Quantity per robot	OMRON Part No.
			CR_UGD4MINI_R
Rotational axis	1 x mounting clamp with cardan joint	1	CR_AS-2938
	1 x complete rotational axis	1	CR_AS-2969
	1 x upper side rotational axis	1	CR_AS-2970
	1 x lower tube with cardan joint and TCP	1	CR_AS-2971
	1 x plain bearing	4	CR_CP-1000



NOTE

For other spare part items, please contact your Omron representative. The spare parts of robots with serial number 1784 or lower will be available up to end of 2022.

■ Models with stainless steel + titanium secondary arms



NOTE

For spare parts of models with stainless steel + titanium secondary arms, please contact your Omron representative.

Chapter 5 Robot settings

Contents

1. Kinematics	5-1
2. Workspace	5-2
3. Software limits	5-3

1. Kinematics

The kinematics parameters for the CR_UGD4MINI robot are shown below. Set these parameters corresponding to the controller settings.



WARNING

IF THE KINEMATICS PARAMETERS ARE NOT SET PROPERLY, THIS MAY CAUSE THE ROBOT TO MALFUNCTION. SO, BE SURE TO SET THESE PARAMETERS CORRECTLY.

Kinematics parameters

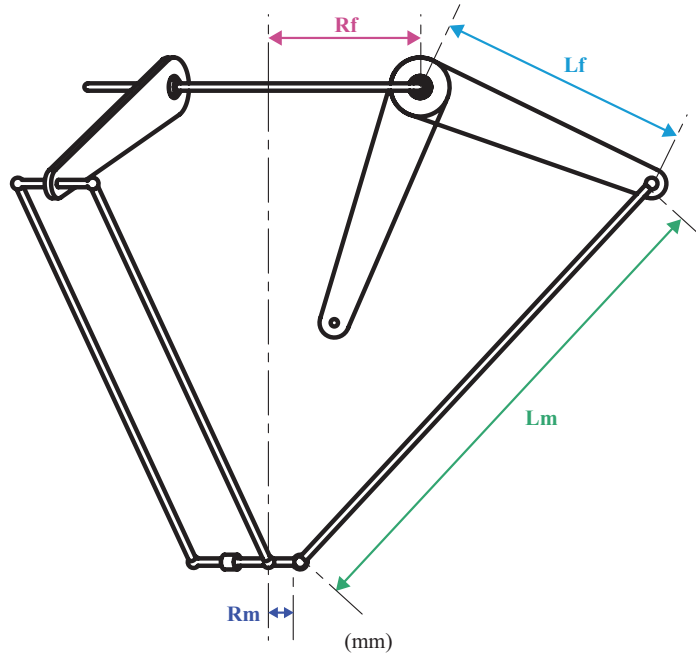

- Rf:** 112 mm Distance (radius) from the center of the fixed frame to the motor of the axis
- Rm:** 40 mm Distance (radius) from the center of the moving frame to the connection point of Link 2
- Lf:** 150 mm Length of Link 1
- Lm:** 435 mm Length of Link 2



NOTE

Robots with serial number 1784 or lower have the next Kinematics parameters: Rf: 100 mm, Rm: 40 mm, Lf: 150 mm, Lm: 400 mm.

2. Workspace

The workspace parameters for the CR_UGD4MINI robot are shown below. Set these parameters corresponding to the controller settings.



WARNING

IF THE WORKSPACE PARAMETERS ARE NOT SET PROPERLY, THIS MAY CAUSE THE ROBOT TO MALFUNCTION. SO, BE SURE TO SET THESE PARAMETERS CORRECTLY.

Workspace parameters

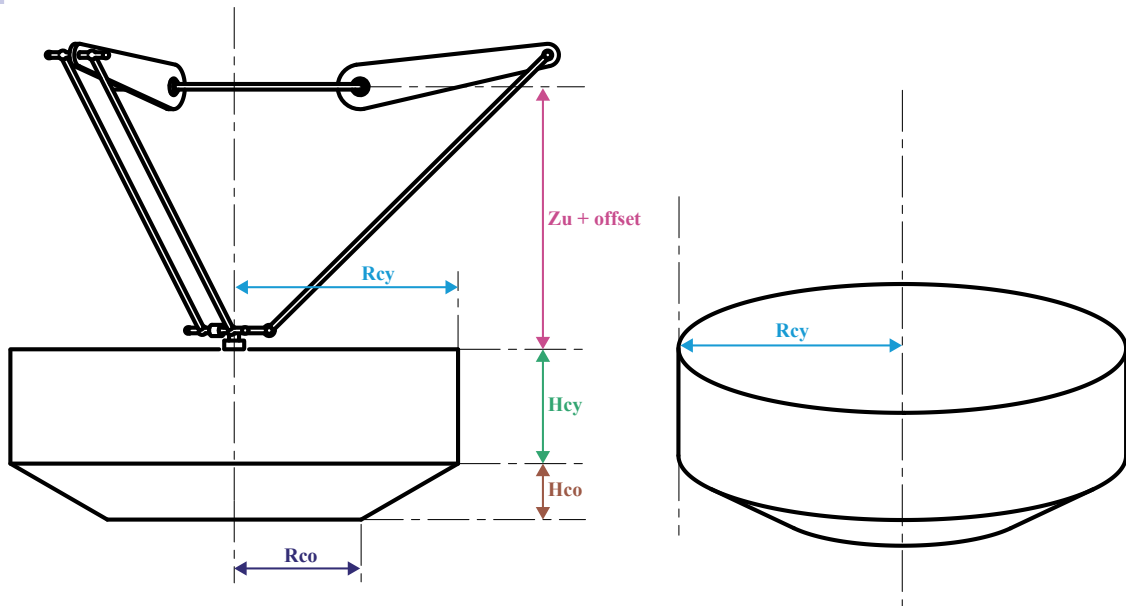

- Zu + offset:** -397,5 mm with rotational axis / -372,5 mm without rotational axis Distance from the Z-axis origin position to the tool flange
- Rcy:** 250 mm Radius of the cylinder
- Hcy:** 130 mm with rotational axis / 155 mm without rotational axis Height of the cylinder
- Rco:** 132,75 mm with rotational axis / 172 mm without rotational axis Radius of the frustum cone of underside
- Hco:** 45 mm Height of the frustum cone



NOTE

Robots with serial number 1784 or lower have the next Workspace parameters: Zu + offset: -408,5 mm with rotational axis/-373,5 mm without rotational axis, Rcy: 225 mm with rotational axis/250 mm without rotational axis, Hcy: 135 mm with rotational axis/155 mm without rotational axis, Rco: 173 mm with rotational axis/172 mm without rotational axis, Hco: 30 mm with rotational axis/45 mm without rotational axis.

3. Software limits

The software limits for the CR_UGD4MINI robot are shown below.



WARNING

IF THE α -, β - OR γ - AXIS SOFT LIMIT IS SET INCORRECTLY, THE ARM MAY COLLIDE WITH THE ROBOT BASE OR BASE PREPARED BY THE USER, CAUSING BREAKAGE. SO, BE SURE TO SET THE SOFT LIMITS CORRECTLY.

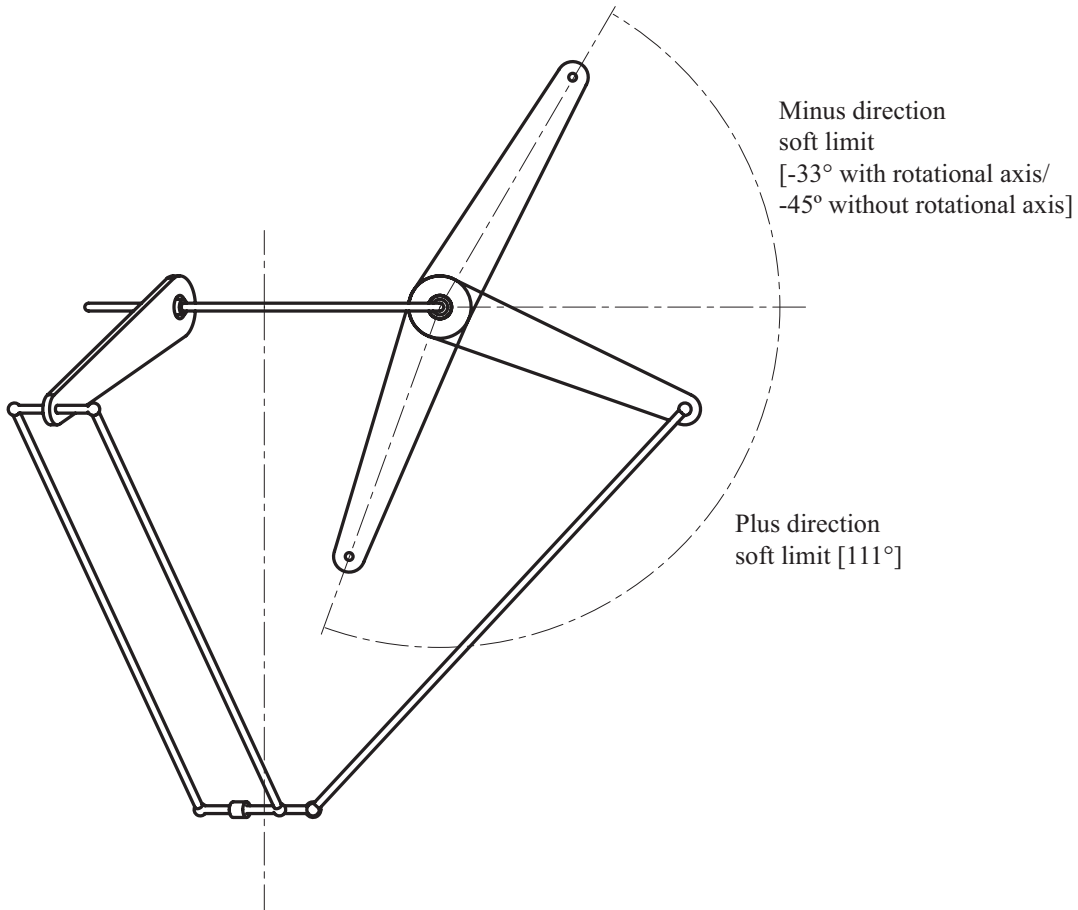

NOTE

Robots with serial number 1784 or lower have the next Software limits: Minus direction soft limit: [-32° with rotational axis/-49° without rotational axis], Plus direction soft limit: [102° with rotational axis/107° without rotational axis].

Chapter 6 Specifications

Contents

1. Basic specifications	6-1
1.1 Cycle time	6-2
2. External view and dimensions	6-3
3. External view and dimensions (Robots with serial number 1784 or lower)	6-4
4. Design specifications	6-5
4.1 Occupation area of robot	6-5
4.2 Software design	6-6
4.2.1 Dimensions and limits	6-7

1. Basic specifications

Robot model			CR_UDG4MINI_ R	CR_UDG4MINI_ NR	CR_UDG4MINI_ R_TS	CR_UDG4MINI_ NR_TS
Working volume	X, Y axis	Stroke	Ø500mm			
	Z axis	Stroke	130mm (max. Ø500mm)	155mm (max. Ø500mm)	130mm (max. Ø500mm)	155mm (max. Ø500mm)
	θ axis	Rotation range	±180° (default setting, it can be changed)			
Servo motor	Arm 1, 2, 3		400W			
	Rotational axis 4		400W		400W	
Repeatability* ¹	X, Y, Z axis		±0.2mm			
	θ axis		±0.3°		±0.3°	
Maximum through-put* ²			200 CPM* ³			
Maximum payload			1kg			
Gearbox ratio	X, Y, Z axis		1:25			
	θ axis		1:1		1:1	
θ axis torque limitation			7Nm		7Nm	
User tubing (outer diameter)			Ø8* ⁴			
Travel limit			Soft limit			
Noise level			< 68 dB (A)			
Ambient temperature			5°C to 45°C			
Relative humidity			Max. 90%			
Protection class			IP65		IP65 (stainless steel + titanium secondary arms)	
Weight			25kg			

*1: This is the value at a constant ambient temperature.

*2: With 0.1kg payload. When reciprocating 305mm in horizontal and 25mm in vertical directions.

*3: CPM: Cycle per minutes. Check the note 2 for the cycle definition.

*4: Only for the air suctioning. The air injection is not allowed.



NOTE

Robots with serial number 1784 or lower have different dimensions. Refer to "3. External view and dimensions (Robots with serial number 1784 or lower)" in Chapter 1 for more detailed information about dimensions.

1.1 Cycle time

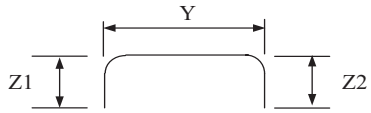

P&P path	Payload	Cycle time
25 x 305 x 25 mm (Z1 x Y x Z2)	0.1 kg	0.30 s
	0.5 kg	0.43 s
	1 kg	0.52 s

2. External view and dimensions

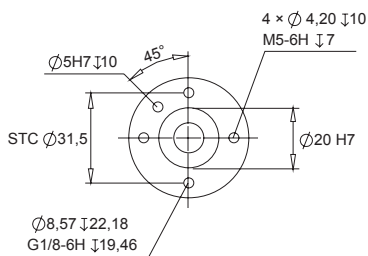
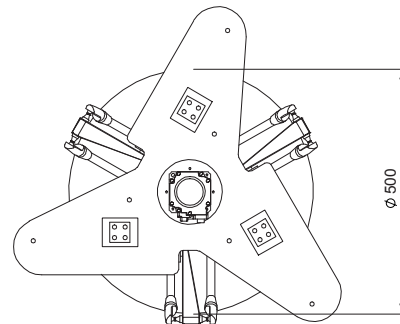
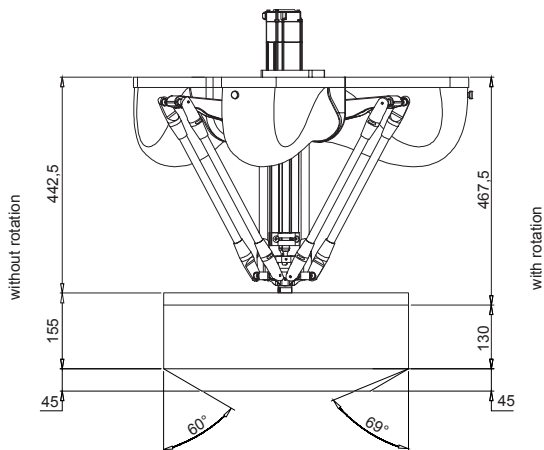
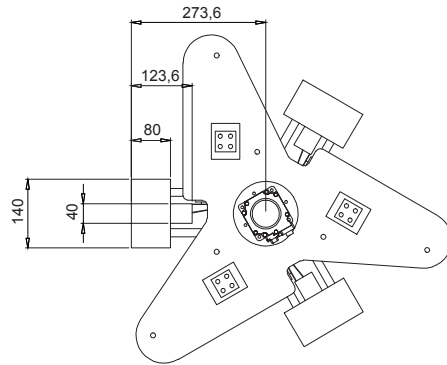
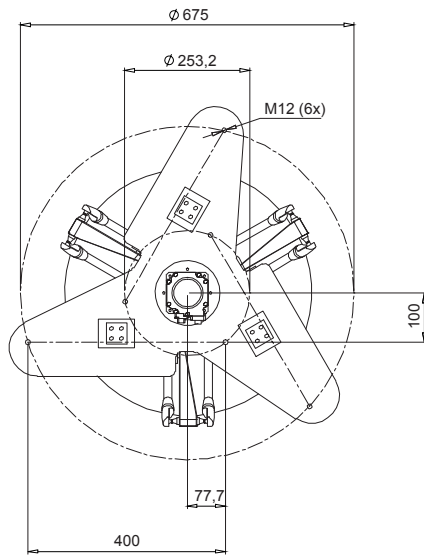

Gripper dimensions

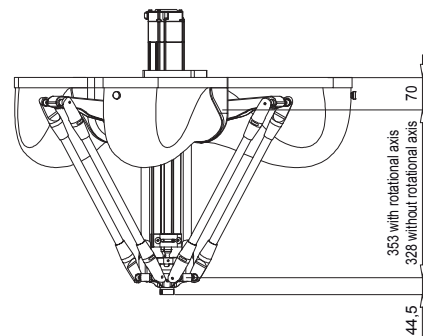

3. External view and dimensions (Robots with serial number 1784 or lower)

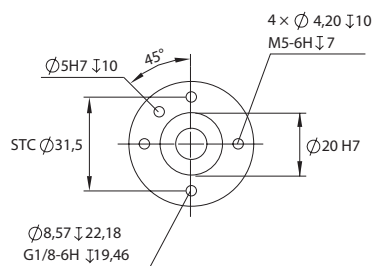
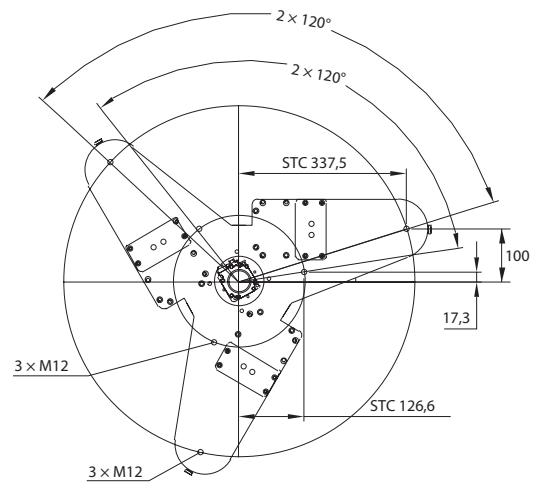
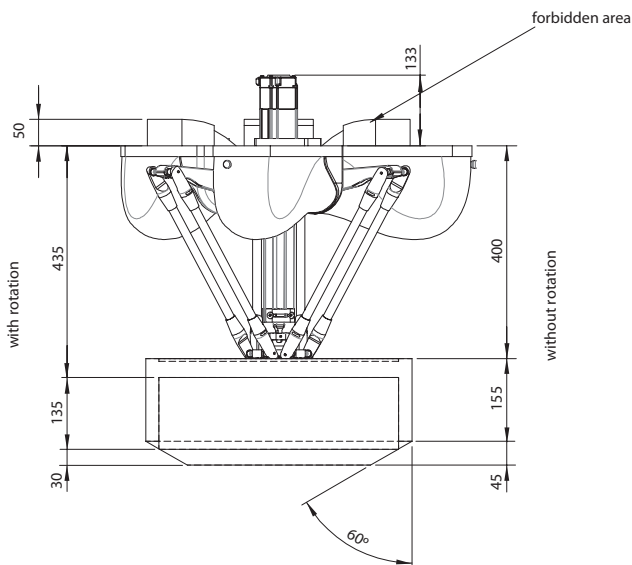
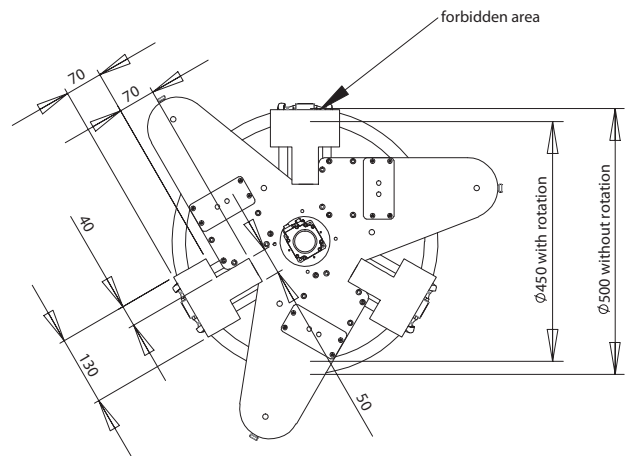
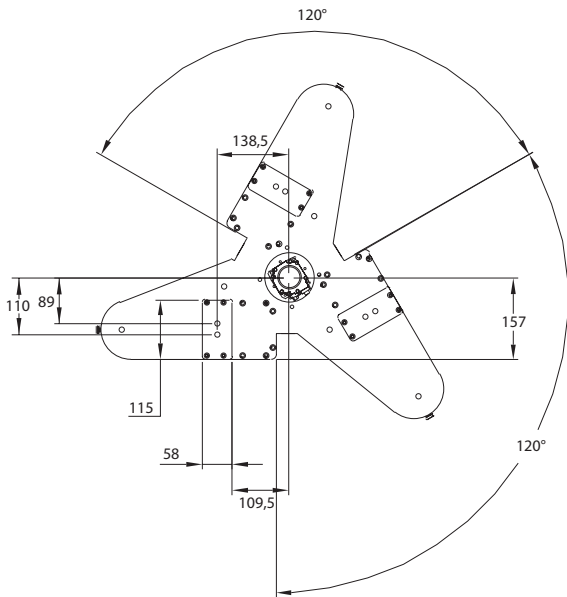

Gripper dimensions

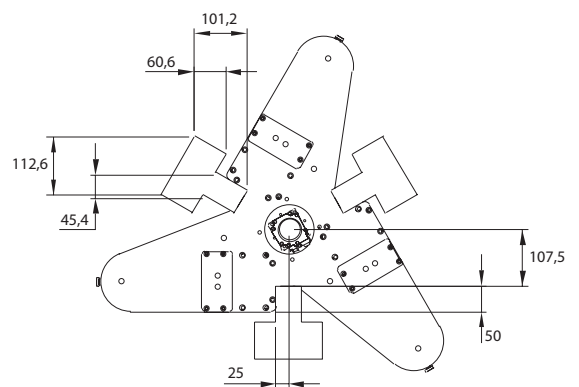

4. Design specifications

4.1 Occupation area of robot

If the robot is integrated into the machine it must be considered what the reach is of all robot parts to prevent collision with other parts in the machine.

When the TCP moves to its outer positions, the primary and secondary arms can rise above the baseplate, take care that no mechanical obstructions are in the areas indicated in the below figure.

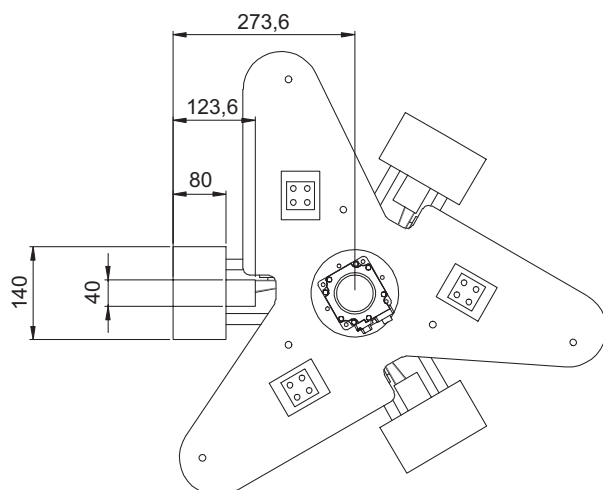

WARNING

IF MECHANICAL OBSTRUCTIONS ARE IN THE INDICATED AREA, THE ROBOT OR THE OTHER MACHINE PARTS COULD BE DAMAGED.



NOTE

Robots with serial number 1784 or lower have different dimensions. Refer to "3. External view and dimensions (Robots with serial number 1784 or lower)" in Chapter 1 for more detailed information about dimensions.

4.2 Software design

The arm lengths and pitch circles of the rotation points are shown in the below picture.

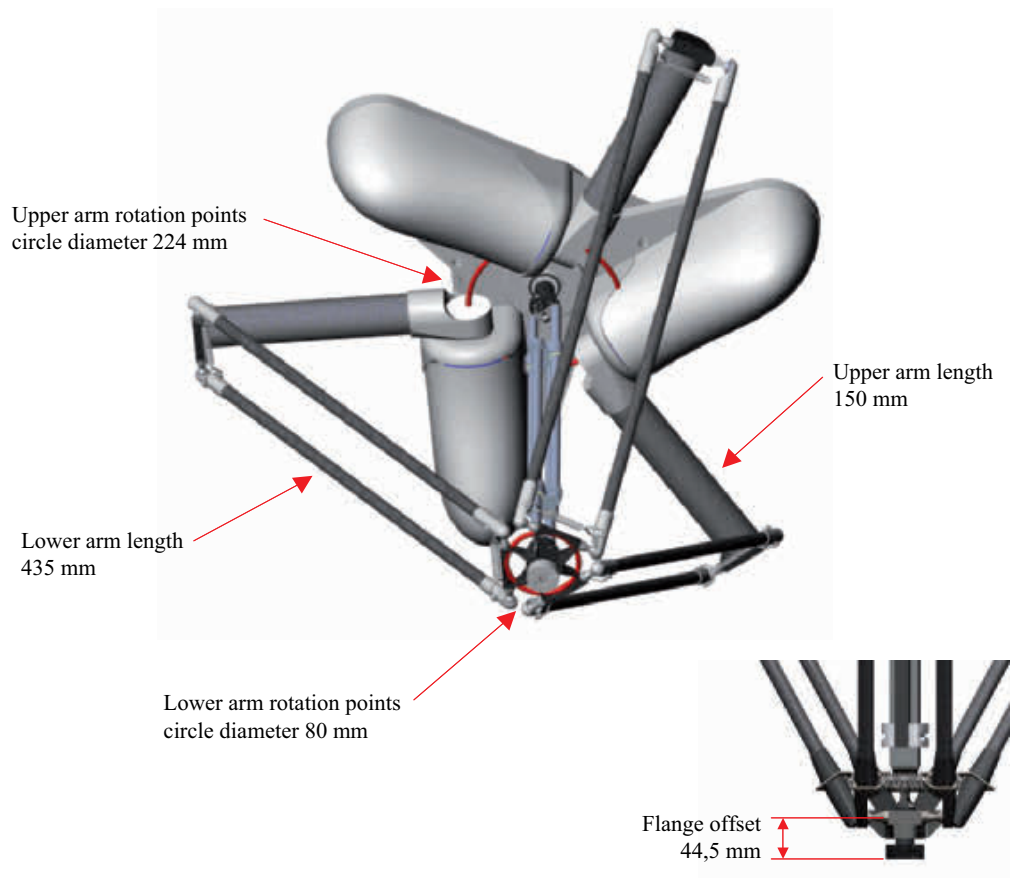

NOTE

Robots with serial number 1784 or lower have different dimensions. Refer to "3. External view and dimensions (Robots with serial number 1784 or lower)" in Chapter 1 for more detailed information about dimensions.

4.2.1 Dimensions and limits

Description	Value	
	With rotational axis	Without rotational axis
Negative software limit	-33°	-45°
Positive software limit	111°	
Tb-z (top baseplate to zero position)	70 mm	
Z-tw (zero position to ball bearings)	353 mm	328 mm
Flange offset	44,5 mm	

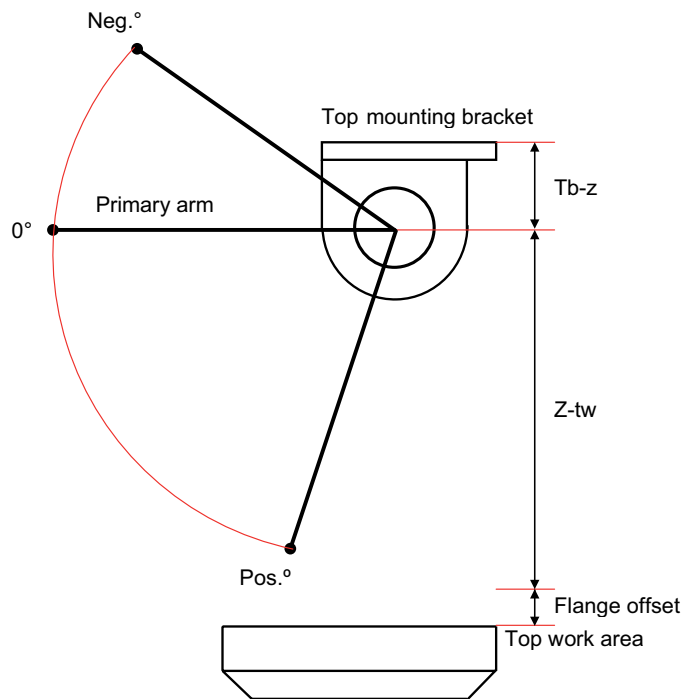

NOTE

Robots with serial number 1784 or lower have the below dimensions and limits: Negative software limit: -32° with rotational axis/-49° without rotational axis, Positive software limit: 102° with rotational axis/107° without rotational axis, Tb-z: 70 mm, Z-tw: 365 mm with rotational axis/330 mm without rotational axis, Flange offset: 43,5 mm.

Revision history

A manual revision code appears as a suffix to the catalog number on the front cover manual.

Cat. No. I198E-EN-02A



The following table outlines the changes made to the manual during each revision.

Revision code	Date	Description
01	April 2016	Original production
01A	July 2016	Dimensions of models with serial number 1784 or lower were added
01B	October 2016	Spare parts section was updated
01C	January 2017	Spare parts section was updated
01D	May 2017	Spare parts section was updated. Robot dimensions were updated
01E	September 2017	Basic specifications section was updated
02	June 2018	Spare part references were modified
02A	March 2020	Torque limitation of rotational axis was modified

OMRON

Authorized Distributor: